

# HJBMX 45 T4 0,37kW Zone 1: FAN (Ex h IIB+H2 T4 Gb) + MOTOR (Ex db IIC T5 Gb) (268453106XD)

## GENERAL DATA



### ATEX SQUARE WALL PLATE FAN WITH VARIABLE PITCH BLADES

#### MANUFACTURING FEATURES

- Square plate made of inox steel AISI 304.
- Variable pitch angle PAGAS (PA6 GF30 AS) impeller.
- Supplied with galvanized motor support and protection guard according to the ROHS 2002/95/EC Directive (Restriction of the Use of Certain Hazardous Substances in Electrical and Electronic Equipments).
- ATEX standard asynchronous motor. ATEX certified: II2G Ex d, Standard voltages 230V 50Hz for single phase motors, 230/400V 50Hz for three phase motors. IP55 protection.

#### APPLICATIONS

Designed for wall assembly, they are suitable for:

- Air renewal in buildings and industries.
- Smoke extraction (max. 60°C).
- General ventilation in closed environments classified as ATEX.
- Working temperature: ambient from -20°C to 60°C

#### UNDER REQUEST

- 60Hz fans and special voltages.
- Stainless protection grid.

ORGANISM: L.O.M.  
CERTIFICAT N°: LOM 17.755X-C

In compliance with the Directive 2014/34/UE

## PERFORMANCE CURVE

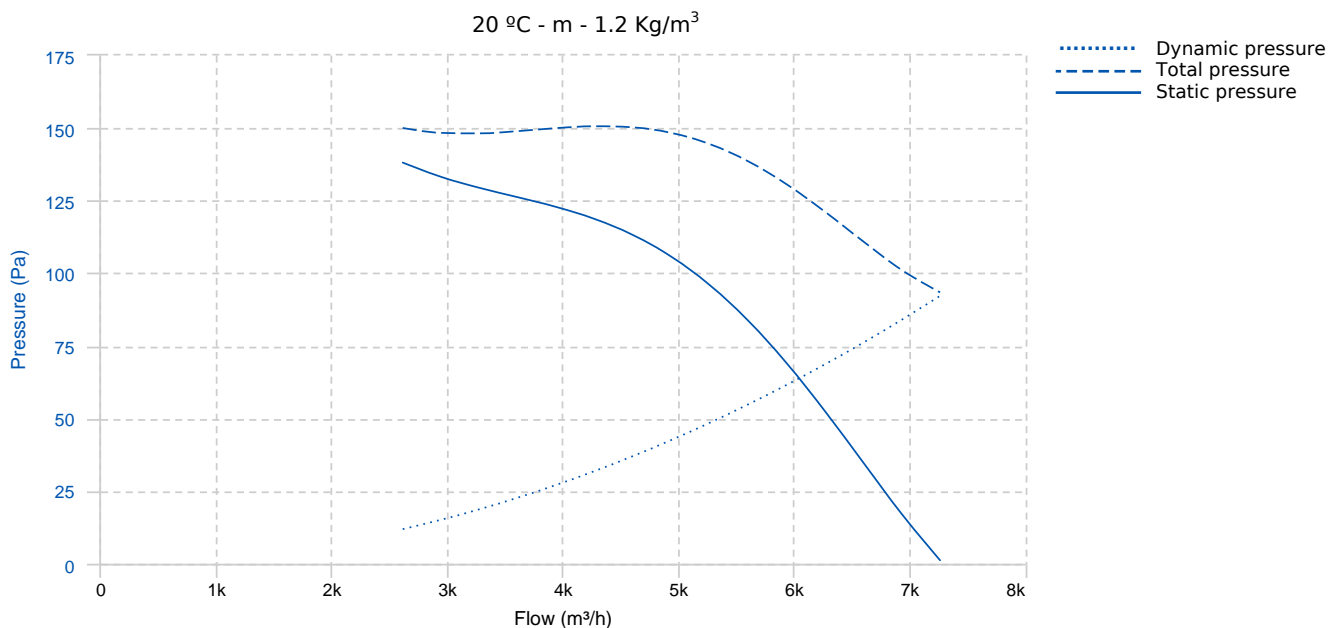

## TECHNICAL DATA

Fan							
RPM	1378	Approx. weight	13 kg	Max. Flow	7270 m <sup>3</sup> /h		
Motor							
Power	0,37 kW	RPM	1378	I max. (400V)	1,25 A	Size	71
Efficiency (%)	56.74 %	FP	0				

## DIMENSIONS

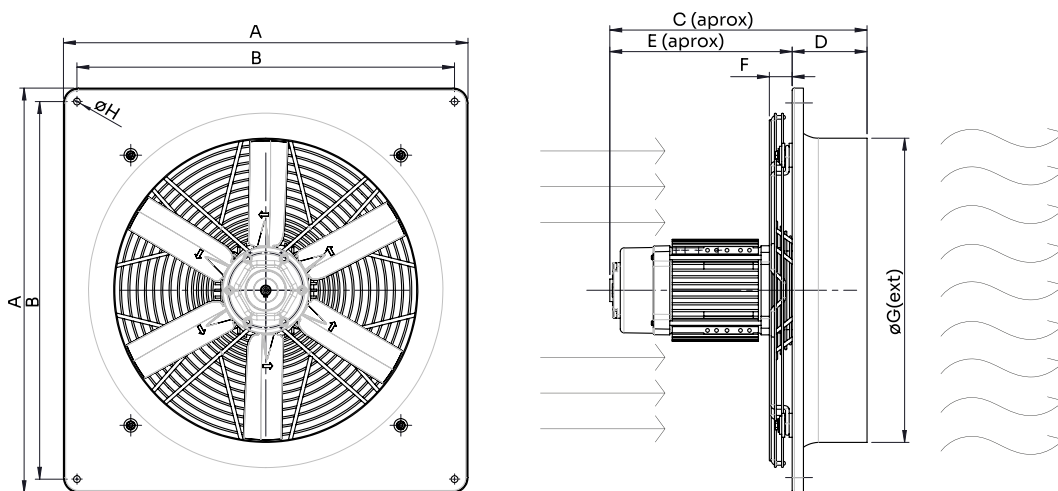

Dimensions (mm)									
A	576	B	521.5	C	340	D	98.5	E	241.5
F	33.5	G	455	H	11				

## WIRING DIAGRAM

230V 

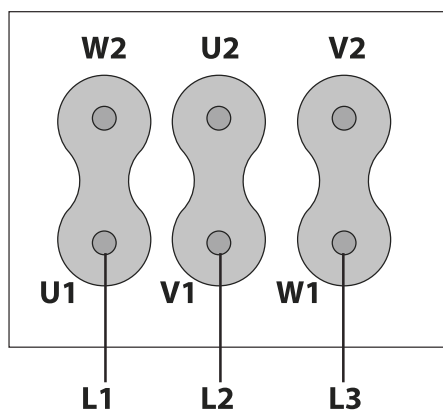

400V 

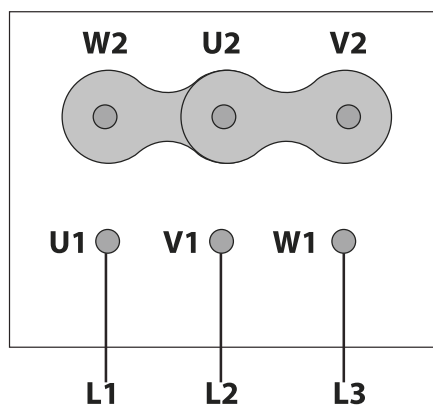

## ACCESSORIES



**Outlet protection guard for axial fans  
RP0 45**  
REF: 980000045



**ATEX SWITCH  
INT 16 ATEX**  
REF: 510200016X



**FREQUENCY SPEED CONTROLLER  
SFC 230 I 4,2A \***  
REF: SFC230I004



**FREQUENCY SPEED CONTROLLER  
SFC 400 III 2,2A \***  
REF: SFC400III2

## SPARE PARTS

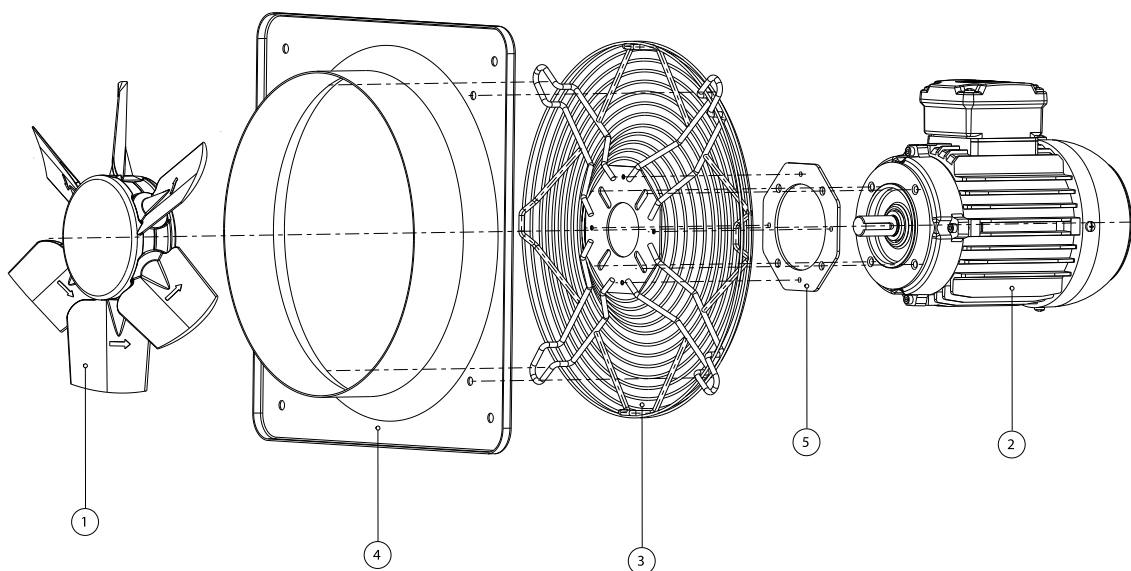

	Code	Model	Qty
2	721601132M050	MOTOR 0,37KW T4 B14	x1